

DIGITAL THERMOSTAT TH132-AF



DIGITAL THERMOSTAT TH132-AF (230 VAC)

SUMMARY

- **OPTIONS SELECTION**
On the inside of the rear side of the thermostat, there are two switches which enable the thermostat to be set according to your preferences:
→ Temperature in °C or °F and the Early Start function – what is known as Fuzzy logic (it's a self-learning thermostat).
- **SETTING THE TIME AND DAY**
Set the time and day using the DAY, HOUR and MIN buttons.
- **SETTING THE DAY ☼ (COMFORT) SETPOINT TEMPERATURE**
Select the required setpoint temperature using the ▲ or ▼ arrow. Press the ☼ button and hold it for 2 – 3 seconds until the ☼ symbol appears on the display.
- **SETTING THE NIGHT ☾ (ECONOMY) SETPOINT TEMPERATURE**
Select the required setpoint temperature using the ▲ or ▼ arrow. Press the ☾ button and hold it for 2 – 3 seconds until the ☾ symbol appears on the display.
- **SETTING THE VACATION 🗑️ SETPOINT TEMPERATURE**
Select the required setpoint temperature using the ▲ or ▼ arrow. Press the 🗑️ button and hold it for 2 -3 seconds until the 🗑️ symbol appears on the display.
- **OPERATING MODES**
To select the operating mode, use the Mode/Return button.
AUTO: Programmes operate in this regime. The ▲ or ▼ arrow will show the setting of the temperature and can temporarily override the programming up until the next programme.
MAN: This regime maintains the set temperature. The temperature setting can be changed using the ▲ or ▼ arrow.

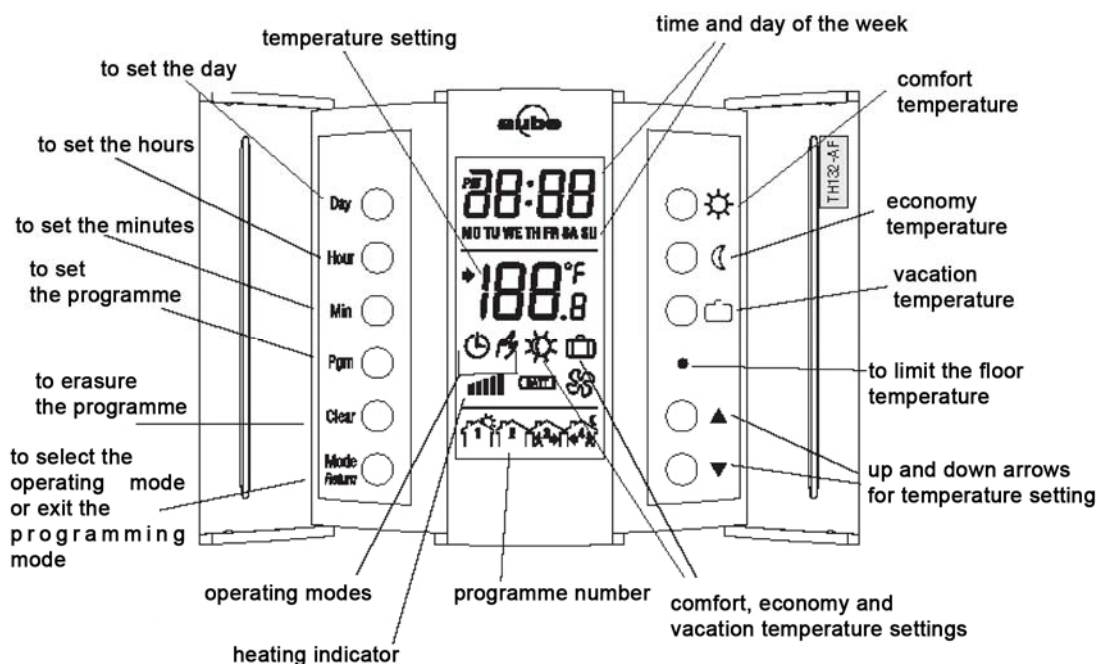

INSTALLATION

The TH132-AF thermostat has two temperature sensors. The first one, installed under the cover in the device, reads the ambient (air) temperature. The second one, installed in the floor, limits the floor temperature. The installation of the thermostat should be carried out by an electrician (a person qualified in accordance with decree 50/1978 Coll.)

The thermostat needs to be connected on a circuit equipped with a fuse or a circuit breaker in a standard electrical box.

For the placement of the thermostat, choose an inside wall, approximately 1.5 m above the floor in a place with free air circulation. Do not place the thermostat in a place where there is direct sunshine or in places where its function could be directly affected by heat created by the operation of certain appliances (television, fridge etc.).

Do not install the thermostat in locations where there are air drafts (the top of a staircase, an air outlet), dead air spots (behind a door), in direct sunlight or on walls where there are chimneys or stove pipes.

BEFORE INSTALLATION, TURN OFF THE POWER TO THE HEATING SYSTEM USING THE PROTECTIVE ELEMENTS IN THE POWER PANEL TO AVOID INJURY FROM ELECTRIC CURRENT.

Keep the air vents of the thermostat clean and free from obstructions.

PARTS INCLUDED

- one (1) TH132-AF (230 VAC) thermostat
- one (1) temperature sensor with a 3 meter lead (can be shortened)
- one (1) wall plate

1. Installation of the thermostat

Before installation, turn off the power to the heating system on the main power panel in order to avoid injury from electric current.

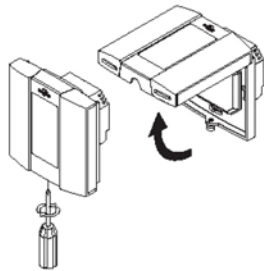

Unscrew and remove the front part of the thermostat from the base plate. The screw cannot be unscrewed completely.

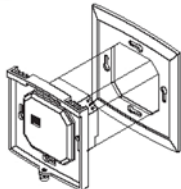

Thermostat with a wall plate

Before making the connections, make sure that the base plate of the thermostat covers the electrical box completely. If not, insert the wall plate between the thermostat and the box.*

* *The wall plate can also be used for aesthetic reasons.*

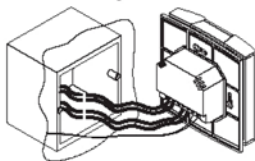

Connect the wires.
(see section 1.1)

Connect the sensor.
(see section 1.2)

Secure the base of the thermostat to the electrical box (KU, KP 68).

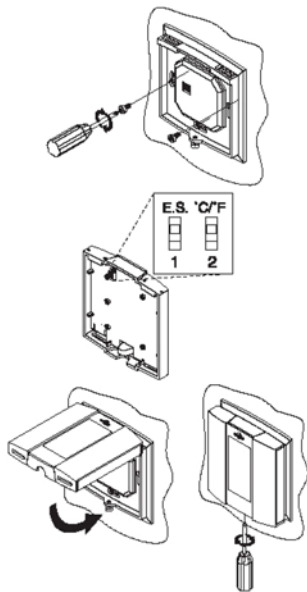

Set the switches which are located at the back of the front part of the thermostat before inserting the front part back into the base (see section 1.3).

Affix the front part of the thermostat to the base using the built-in screw. You can turn the power back on now.

1.1 Connection

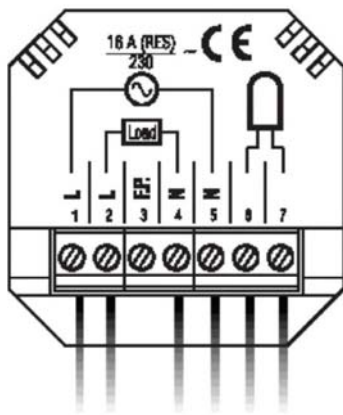

F. P: unconnected

Connecting terminal

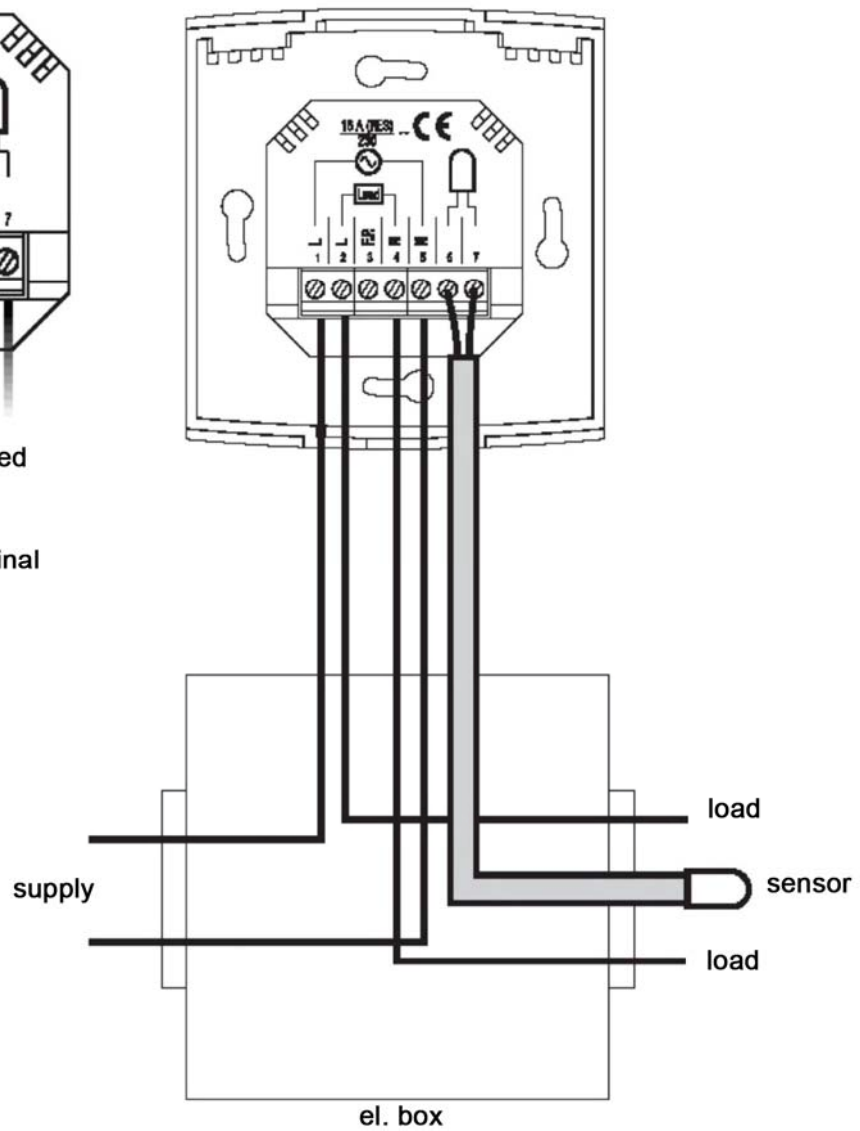

Connecting the temperature sensor

Connect the wires of the temperature sensor to the terminals on the rear side of the thermostat (no polarity needs to be respected).

Note: Do not install the floor probe immediately next to a heating element. Insert the probe between the heating cables (it mustn't touch them), approx. 20 cm deep into the heating area, as close to the surface as possible. The cable of the temperature sensor mustn't lie across the heating cables.

Setting the maximum temperature of the floor

Check the set temperature of the floor during the installation of the floor sensor. The recommended value is 27–33 °C (depending on the type of room). To adjust the setting of the maximum floor temperature, press the adjustment button (you can see the position of the button in the picture) using a pointed object and the ▲ or ▼ arrows.

1.2 Configuration of switches

a) Early Start function, known as Fuzzy Logic

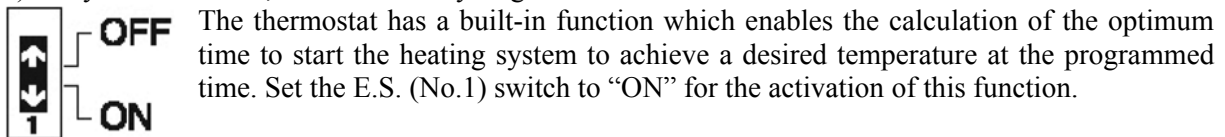

b) Temperature in °C or °F

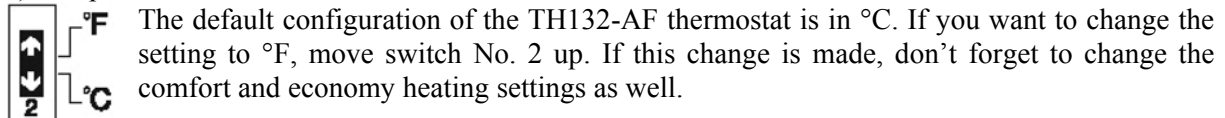

POWERING UP THE THERMOSTAT

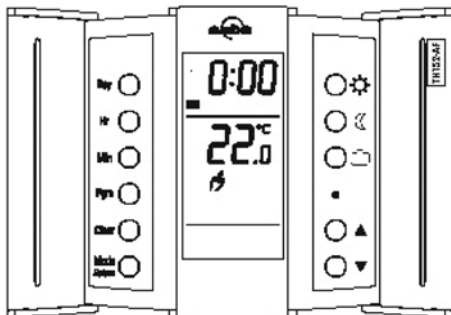

When the thermostat is switched on for the first time, the display will show the time 0:00, the temperature, and the manual mode (M) symbol. If the thermostat is defective or doesn't comply with the instructions, other information may appear.

If the temperature sensor is defective, or if the temperature is lower than 0 °C or higher than 60 °C, the message LO or HI will appear on the display. If the LO message is displayed, the heating indicator will also appear and the relay will be closed (the current is going in the load).

OPERATING MODES

The TH132-AF thermostat has two (2) operating modes.

MAN – manual mode (🌀)

This mode enables the maintenance of a constant temperature.

1. To activate this mode, press the Mode/Return button. The 🌀 symbol will appear.
2. Set the desired temperature using the ▲ or ▼ arrows, or use the settings which are programmed for day, night or vacation operation (☼, ☾, 🏠).

AUTO – automatic mode (🕒)

This mode executes your own programming.

To activate this mode, press the Mode/Return button. The 🕒 symbol will be displayed. The ☼ and ☾ symbols indicate which temperature setting is used. Also, the number of the programme will be shown.

Vacation function

This function sets your thermostat to your specified vacation temperature.

If you are to be absent for a longer period, set the vacation heating using the 🏠 button. The display will show the 🏠 symbol. The temperature will remain at this setting until it is returned to the normal operating mode using the Mode/Return button. If you wish to return to the programmed setting immediately, press the Mode/Return button.

PROGRAMMING

Programming the time and day

1. Set the time using the Hour and Min (minute) buttons.
2. Set the day using the Day button.

Programming the comfort, economy and vacation settings





The comfort temperature ☼ is the temperature that you wish to be set during the day, the economy temperature ☾ is set for the night or for periods when you are at work, and the vacation temperature 🏠 is set for a longer period of absence.

Programming:

- a) Select the desired comfort temperature setpoint using the ▲ or ▼ arrows and press the ☼ button (hold for about 3 seconds). The ☼ symbol will appear on the display.
- b) Select the desired economy temperature setpoint using the ▲ or ▼ arrows and press the ☾ button (hold for about 3 seconds). The ☾ symbol will appear on the display.
- c) Select the desired vacation temperature setpoint using the ▲ or ▼ arrows and press the 🏠 button (hold for about 3 seconds). The 🏠 symbol will appear on the display.
- d) Press the Mode/Return button to exit this function and return to the normal operation mode.

Day by day schedule programming

The TH132-AF thermostat allows the setting of 4 different programmes for each day of the week. There are no pre-set programmes. The programs are designed in such a way that they perfectly adapt to your life style. The principle is very simple. For each day, enter the time when you wake up (P1), the time you leave for work (P2), the time you arrive back home (P3) and the time you go to bed (P4).

Programme	Mode	Time
	☀ comfort	Wake-up time
	☾ economy	Leaving time
	☀ comfort	Return time
	☾ economy	Bed time

For economical operation, you must lower the temperature for a period at least 2 times longer than the delay required to bring the temperature back to the comfort level.

Example: If your system takes one hour to get from the economy temperature to the comfort temperature, nothing is gained by lowering the temperature for a period shorter than two hours.

a) Programming your schedule

1. Press the Pgm button to access the programming mode.
2. Press the Day button and select the day to be programmed. You can select all of the days of the week at the same time by pressing the Day button for a period of 3 seconds.
3. Press the Pgm button and select programme 1, 2, 3 or 4.
4. Set the time using the Hour and Min buttons.
5. When you have finished programming, exit the function by pressing the Mode/Return button.

b) Erasing a programme

Select the programme using the Pgm and Day buttons and press the Clear button. If the programme is not active, the time field will display -:-.

- c) Example 1:** Setting of the comfort temperature from 7:00 to 22:30
 Setting of the economy temperature from 22:30 to 7:00
 Identical setting of programmes for all the days of the week

Prog./day	Monday	Tuesday	Wednesday	Thursday	Friday	Saturday	Sunday
PROG. 1 ☀	7:00	7:00	7:00	7:00	7:00	7:00	7:00
PROG. 2 ☾	---	---	---	---	---	---	---
PROG. 3 ☀	---	---	---	---	---	---	---
PROG. 4 ☾	22:30	22:30	22:30	22:30	22:30	22:30	22:30

1. Press the Pgm button to access the programming mode.
2. Press the Day button and hold it for 3 seconds to select all the days of the week.
3. Press the Hour button and enter 7:00 into Prog. 1 (☀)
4. Press the Pgm button three times to select Prog. 4 (☾) and then press the Hour and Min buttons and enter 22:30.
5. Press the Mode/Return button to exit this function.

d) Example 2: Setting of comfort temperature

Monday to Friday from 6:15 to 8:15 and from 17:00 to 22:00,
on Saturday and Sunday from 7:30 to 23:00

Prog./day	Monday	Tuesday	Wednesday	Thursday	Friday	Saturday	Sunday
PROG. 1 ✱	6:15	6:15	6:15	6:15	6:15	7:30	7:30
PROG. 2 ☹	8:15	8:15	8:15	8:15	8:15	---	---
PROG. 3 ✱	17:00	17:00	17:00	17:00	17:00	---	---
PROG. 4 ☹	22:00	22:00	22:00	22:00	22:00	23:00	23:00

Note: It is faster to programme all days in the same way and then change the days which are different.

1. Press the Pgm (programming) button to access the programming mode.
2. Press the Day button and hold it for 3 seconds to select all the days of the week.
3. Press the Hour and Min buttons and enter 6:15 into Prog.1 (✱).
4. Press the Pgm button and select Prog.2 (☹) and then record the time 8:15 using the Hour and Min buttons.
5. Repeat step 4 to set Prog. 3 (17:00) and Prog. 4 (22:00).

Note: When making modifications, always check that you are in the right programme.

Modification of Saturday and Sunday settings

6. Press the Day button and select SA (Saturday) or SU (Sunday).
7. Press the Pgm button to select Prog. 1 (✱) and record the time 7:30 using the Hour and Min buttons.
8. Press the Pgm button to select Prog. 2 (☹) and then erase it by pressing the button Clear.
9. Press the Pgm button to select Prog. 3 (✱) and then erase it by pressing the button Clear.
10. Press the Pgm button to select Prog. 4 (☹) and record the time 23:00 using the Hour and Min buttons.
11. Press the Mode/Return button to exit this function.

Memory back-up

In the event of a power failure, an internal circuit will maintain the programming and the time. If the power failure exceeds two hours, only the time will need to be set again.

Manual – for a short-term change in temperature

This function allows a temporary change of temperature in the automatic mode. Simply select the required temperature using the ▲ or ▼ arrows or select the comfort or economy setting which you have programmed, using the ✱ or ☹ buttons. This temperature will be maintained until the beginning of the next programme. If you wish to immediately return to the programmed setting, press the Mode/Return button twice.

Use of only one probe

The thermostat is equipped with two temperature probes. The floor probe (a cable sensor) is detachable but the thermostat is not able to function in a standard way without this sensor. You can put the individual sensor out of operation by setting the maximum temperature in the programme, which cannot be practically achieved. For example, when using the floor temperature sensor only, set the night (economy) temperature to the lowest possible value, +5 °C. During this time, the thermostat won't switch on the heating because the temperature in the room will not drop to +5 °C during normal operation. For the time when we want the thermostat to switch on the heating, we'll set the day (comfort) temperature to the highest possible value, +30 °C, as it is expected that this temperature will never be reached in the room. We'll set the desired floor temperature on the floor sensor and the thermostat will work as an on/off switch. On the other hand, when the temperature on the floor sensor is set to +40 °C and the room sensor has the standard programme and temperature settings, we'll achieve taking the floor sensor (probe) out of operation, as this temperature will never be reached during ordinary heating.

TECHNICAL PARAMETERS

Model:	TH132-AF
Supply:	230 VAC 50 Hz
Load	
- resistive:	16 A max.
- inductive (necessitates use of SNUBBER AC 130-03):	2 A max.
Power:	3680 W at 230 VAC
Approvals:	EN60730-2-9 EN50081-1 / EN50082-2
Display range:	0–60 °C
Setting range, ambient temperature:	5–30 °C
Setting range, floor temperature:	5– 40 °C
✳ default setting:	20 °C
☺ default setting:	18 °C
■ default setting:	10 °C
Storage:	-20 to 50 °C
Software:	Class A
Controller:	Electronic
Protection:	Class 2
Protection degree:	IP20
Automatic action:	Type 1B
Environment:	Normal pollution level
Programming protection:	Memory back-up
Clock protection:	2 hours
Dimensions (w × h × d):	79 × 83 × 13 mm

The terminals are designed for a wire with a cross-section of 0.33 to 3.1 mm².

WARRANTY

For normal use, a 2-year warranty from the date of purchase from an authorized seller is provided for flaws in the material or which occurred during the manufacturing of this product.

The warranty doesn't include transportation costs or costs of installation, uninstalling and re-installation. The warranty doesn't apply to products which have been damaged by improper use.

In the case of any questions regarding the installation or programming of this product, please call our technical assistance helpline.

THERMOSTAT FAULT DESCRIPTION FORM

To speed up the proceedings, please specify the fault.

Description of the switched load, wattage (for example: heating mat, 1 400 W):	
Put a cross next to the fault; you can also add details.	
<input type="checkbox"/>	The thermostat is attached to a power source, the display is not lit.
<input type="checkbox"/>	The thermostat is attached to a power source, the display is lit, but it doesn't react.
<input type="checkbox"/>	The thermostat is set and placed correctly, the target temperature is not achieved but it doesn't switch on.
<input type="checkbox"/>	The thermostat is set and placed correctly, the target temperature is achieved but it doesn't switch off.
<input type="checkbox"/>	The thermostat sets itself to zero when the tariff changes from high to low.
Other fault:	

If you wish to make a complaint, please copy this sheet and enclose it with the thermostat.



Fenix Trading s.r.o.

Slezská 2, 790 01 Jeseník, Czech Republic

tel.: +420 584 495 304, fax: +420 584 495 303

e-mail: fenix@fenixgroup.cz • <http://www.fenixgroup.cz>